

Lineární vedení

Typ EG/QW

2.1.14.2

EGW / QEW - SC

EGW / QEW - CC

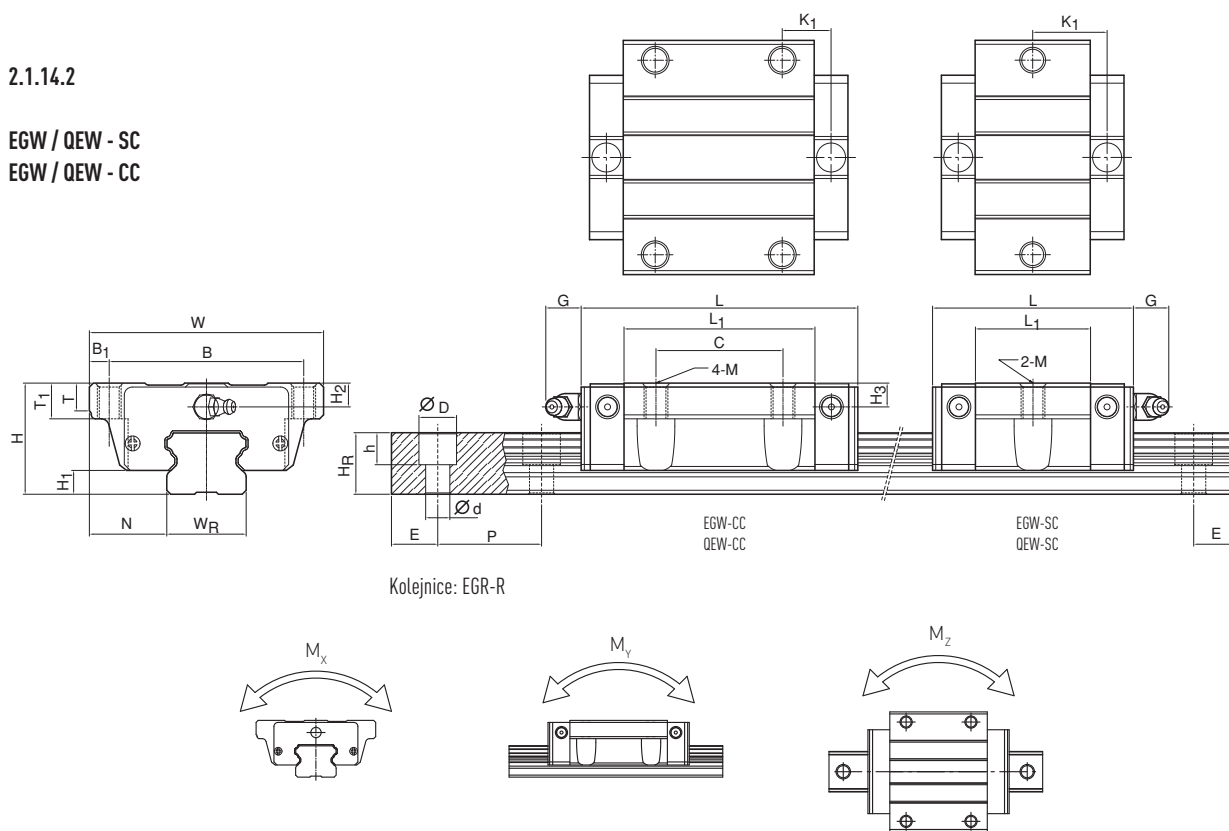

Kolejnice: EGR-R

Typ	Montážní rozměry [mm]		Rozměry vozíku [mm]														Rozměry kolejnice [mm]										Šrouby pro kolejnici [mm]	Dynamická únosnost C_{dyn} [N]		Statická únosnost C_0 [N]			Statický moment			Hmotnost	
			H	H ₁	N	W	B	B ₁	C	L ₁	L	G	MXL	K ₁	T	H ₂	H ₃	W _R	H _R	D	h	d	P	E	M _x [Nm]	M _y [Nm]							M _z [Nm]	Vozík [kg]	Kolejnice [kg/m]		
EGW15SC	24	4,5	18,5	52	41,1	5,5	-	23,1	40,1	5,7	M5	14,80	5,0	5,5	6,0	15	12,5	6,0	4,5	3,5	60	*	M3x16	5350	9400	80	40	40	0,12	1,25							
EGW15CC		26					39,8	56,8	10,15			7830												16190	130	100	100	0,21									
QEW15SC		-					23,1	40,1	14,80			8560												8790	70	30	30	0,12									
QEW15CC		26					39,8	56,8	10,15			12530												15280	120	90	90	0,21									
EGW20SC	28	6,0	19,5	59	49,0	5,0	-	29,0	50,0	12,0	M6	18,75	7,0	6,0	6,0	20	15,5	9,5	8,5	6,0	60	*	M5x16	7230	12740	130	60	60	0,19	2,08							
EGW20CC							32	48,1	69,1			12,30												10310	21130	220	160	160	0,32								
QEW20SC							-	29,0	50,0			18,75												11570	12180	130	50	50	0,19								
QEW20CC							32	48,1	69,1			12,30												16500	20210	210	150	150	0,31								
EGW25SC	33	7,0	25,0	73	60,0	6,5	-	35,5	59,1	12,0	M8	21,90	7,5	8,0	8,0	23	18,0	11	9,0	7,0	60	*	M6x20	11400	19500	230	120	120	0,35	2,67							
EGW25CC		35					59,0	82,6	16,15			16270												32400	380	320	320	0,59									
QEW25SC		-					35,5	60,1	21,90			18240												18900	220	100	100	0,34									
QEW25CC		35					59,0	83,6	16,15			26030												31490	370	290	290	0,58									
EGW30SC	42	10,0	31,0	90	72,0	9,0	-	41,5	69,5	12,0	M10	26,75	7,0	8,0	9,0	28	23,0	11	9,0	7,0	80	*	M6x25	16420	28100	400	210	210	0,62	4,35							
EGW30CC							40	70,1	98,1			21,05												23700	47460	680	550	550	1,04								
QEW30SC							-	41,5	67,5			25,75												26270	27820	400	180	180	0,61								
QEW30CC							40	70,1	96,1			20,05												37920	46630	670	510	510	1,03								
EGH 35SA	48	11,0	33,0	100	82,0	9,0	-	45,0	75,0	12,0	M10	28,50	10,0	8,5	8,5	34	27,5	14,0	12,0	9,0	80	*	M8x25	22660	37380	560	310	310	0,91	4,35							
EGH 35CA							50	78,0	108,0			20,00												33350	64840	980	690	690	1,40								
QEH 35SA							-	51,0	76,0			30,30												36390	36430	610	330	330	0,77								
QEH 35CA							50	83,0	108,0			21,30												51180	59280	1000	750	750	1,19								

* Pokud zákazník neurčí jinak, oba konce E₁ a E₂ jsou symetrické v rozmezí E_{1/2} min. - a E_{1/2} max. - viz tab. 2.19.