

serie H2300

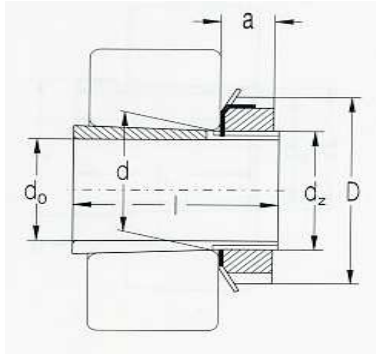

Adapter number	Dimensions						Appropriate Nut	Appropriate Locking	Weight kg
	d0	d	dZ	D	l	a			
H 2304	17	20	M20*1	32	31	7	KM4	MB4	0,049
H 2305	20	25	M25*1,5	38	35	8	KM5	MB5	0,087
H 2306	25	30	M30*1,5	45	38	8	KM6	MB6	0,126
H 2307	30	35	M35*1,5	52	43	9	KM7	MB7	0,165
H 2308	35	40	M40*1,5	58	46	10	KM8	MB8	0,224
H 2309	40	45	M45*1,5	65	50	11	KM9	MB9	0,280
H 2310	45	50	M50*1,5	70	55	12	KM10	MB10	0,362
H 2311	50	55	M55*2	75	59	12	KM11	MB11	0,420
H 2312	55	60	M60*2	80	62	13	KM12	MB12	0,481
H 2313	60	65	M65*2	85	65	14	KM13	MB13	0,557
H 2315	65	75	M75*2	98	73	15	KM15	MB15	1,050
H 2316	70	80	M80*2	105	78	17	KM16	MB16	1,280
H 2317	75	85	M85*2	110	82	18	KM17	MB17	1,450
H 2318	80	90	M90*2	120	86	18	KM18	MB18	1,690
H 2319	85	95	M95*2	125	90	19	KM19	MB19	1,920
H 2320	90	100	M100*2	130	97	20	KM20	MB20	2,150
H 2322	100	110	M110*2	145	105	21	KM22	MB22	2,740
H 2324	110	120	M120*2	155	112	22	KM24	MB24	3,190
H 2326	115	130	M130*2	165	121	23	KM26	MB26	4,600
H 2328	125	140	M140*2	180	131	24	KM28	MB28	5,550
H 2330	135	150	M150*2	195	139	26	KM30	MB30	6,630
H 2332	140	160	M160*3	210	147	28	KM32	MB32	9,140
H 2334	150	170	M170*3	220	154	29	KM34	MB34	10,200
H 2336	160	180	M180*3	230	161	30	KM36	MB36	11,300
H 2338	170	190	M190*3	240	169	31	KM38	MB38	12,600
H 2340	180	200	M200*3	250	176	32	KM40	MB40	13,900