

serie UKP

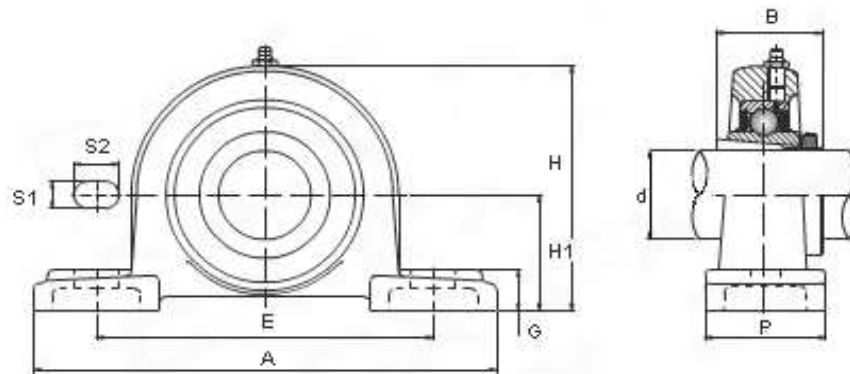

Shaft (mm)	Unit No.	Dimension (mm)											Weight (kg)	Composition		
		d	H1	A	E	P	S1	S2	G	H	B	bolt size		Bearing	Sleeve	Housing
20	UKP 205	20	36,5	140	105	38	13	19	15	71	35	M10	0,86	UK 205	H 2305	P 205
25	UKP 206	25	42,9	165	121	48	17	20	17	84	38	M14	1,28	UK 206	H 2306	P 206
30	UKP 207	30	47,6	167	127	48	17	20	18	93	43	M14	1,67	UK 207	H 2307	P 207
35	UKP 208	35	49,2	184	137	54	17	20	18	100	46	M14	1,99	UK 208	H 2308	P 208
40	UKP 209	40	54	190	146	54	17	20	20	106	50	M14	1,29	UK 209	H 2309	P 209
45	UKP 210	45	57,2	206	159	60	20	23	21	113	55	M16	2,83	UK 210	H 2310	P 210
50	UKP 211	50	63,5	219	171	60	20	23	23	125	59	M16	3,46	UK 211	H 2311	P 211
55	UKP 212	55	69,8	241	184	70	20	23	25	138	62	M16	4,95	UK 212	H 2312	P 212
60	UKP 213	60	76,2	265	203	70	25	28	27	150	65	M20	5,06	UK 213	H 2313	P 213
65	UKP 215	65	82,6	275	217	74	25	28	28	162	73	M20	7,27	UK 215	H 2315	P 215
70	UKP 216	70	88,9	292	232	78	25	28	30	174	78	M20	8,36	UK 216	H 2316	P 216
75	UKP 217	75	95,2	310	247	83	25	28	32	185	82	M20	10,23	UK 217	H 2317	P 217
80	UKP 218	80	101,6	327	262	88	27	30	33	198	86	M22	12,34	UK 218	H 2318	P 218