

serie UKT

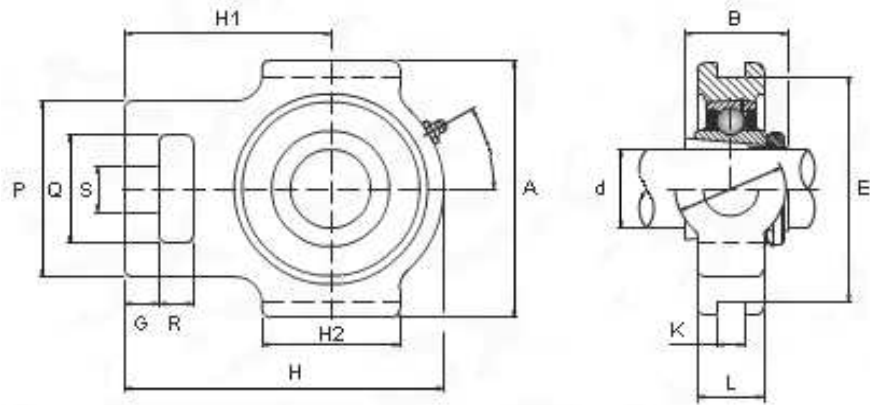

Shaft (mm)	Unit No.	Dimension (mm)															Weight (kg)	Composition		
		d	B	A	P	E	H	H1	H2	G	K	L	R	Q	J	S		Bearing	Sleeve	Housing
20	UKT 205	20	35	89	51	76	97	51	51	10	12	24	16	32	24	19	0,86	UK 205	H 2305	T 205
25	UKT 206	25	38	102	56	89	113	57	57	10	12	28	16	37	28	22	1,26	UK 206	H 2306	T 206
30	UKT 207	30	43	102	64	89	129	64	64	13	12	30	16	37	30	22	2,5	UK 207	H 2307	T 207
35	UKT 208	35	46	114	83	102	144	83	83	16	16	35	19	49	35	29	2,5	UK 208	H 2308	T 208
40	UKT 209	40	50	117	83	102	144	83	83	16	16	35	19	49	35	29	2,51	UK 209	H 2309	T 209
45	UKT 210	45	55	117	83	102	149	86	86	16	16	35	19	49	35	29	2,6	UK 210	H 2310	T 210
50	UKT 211	50	59	146	102	130	171	95	95	19	22	41	25	64	41	35	4,26	UK 211	H 2311	T 211
55	UKT 212	55	62	146	102	130	194	102	102	19	22	46	32	64	46	35	5,02	UK 212	H 2312	T 212
60	UKT 213	60	65	167	111	151	224	121	121	21	26	51	32	70	51	41	6,56	UK 213	H 2313	T 213
65	UKT 215	65	73	167	111	151	232	121	121	21	26	48	32	70	48	41	7,52	UK 215	H 2315	T 215
70	UKT 216	70	78	184	111	165	235	121	121	21	26	51	32	70	51	41	8,56	UK 216	H 2316	T 216
75	UKT 217	75	82	198	124	173	260	157	157	29	30	54	38	73	54	48	11,38	UK 217	H 2317	T 217