

GE .. SX  
serie

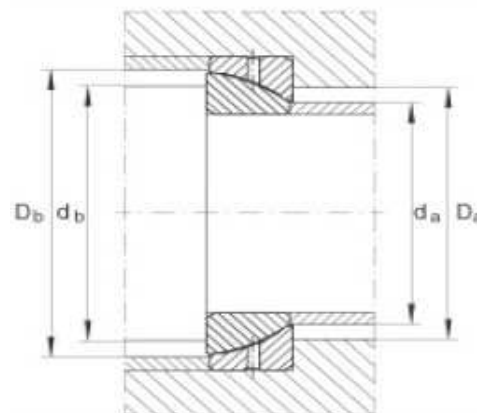
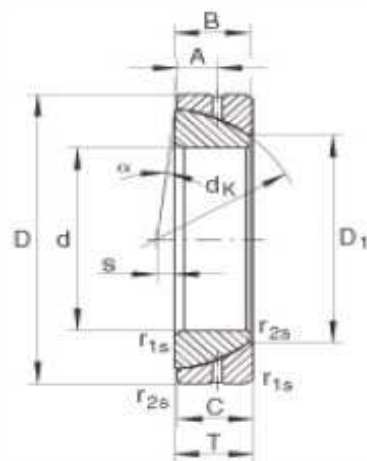

Product No.	Dimensions																Load rating (kN)		Weight kg
	d	D	T	A	B	C	D <sub>1</sub>	Da min	Db min	da max	db max	dk	r15 min	r25 min	s	α	Dynamic	Static	
GE 25 SX	25	47	15	7,5	14	14	31,4	34,0	43,0	30,1	39,5	42,5	0,6	0,2	1,0	2,7	47.500	236.000	0,14
GE 28 SX	28	52	16	8,0	15	15	35,7	40,0	47,5	34,4	42,0	47,0	1,0	0,3	1,0	2,4	57.500	287.000	0,18
GE 30 SX	30	55	17	8,5	16	16	36,1	40,5	50,5	34,6	45,0	50,0	1,0	0,3	2,0	2,3	64.600	323.000	0,21
GE 35 SX	35	62	18	9,0	17	17	42,4	47,0	57,0	41,1	50,0	56,0	1,0	0,3	2,0	2,1	76.500	390.000	0,27
GE 40 SX	40	68	19	9,5	18	18	46,8	52,0	61,0	45,5	54,0	60,0	1,0	0,3	1,5	1,9	90.000	450.000	0,33
GE 45 SX	45	75	20	10,0	19	19	52,9	58,0	67,0	51,7	60,0	66,0	1,0	0,3	1,5	1,7	106.000	530.000	0,42
GE 50 SX	50	80	20	10,0	19	19	59,1	65,0	75,0	57,9	67,0	74,0	1,0	0,3	4,0	1,6	118.000	590.000	0,46
GE 55 SX	55	90	23	11,5	22	22	62,0	70,0	81,0	60,7	71,0	80,0	1,5	0,6	4,0	1,4	146.000	735.000	0,68
GE 60 SX	60	95	23	11,5	22	22	68,1	76,0	87,0	66,9	77,0	86,0	1,5	0,6	5,0	1,3	160.000	802.000	0,73
GE 65 SX	65	100	23	11,5	22	22	75,6	84,0	93,0	74,4	83,0	92,0	1,5	0,6	5,0	1,3	173.000	865.000	0,77
GE 70 SX	70	110	25	12,5	24	24	82,2	90,0	104	80,9	92,0	102	1,5	0,6	7,0	1,1	208.000	1.040.000	1,10
GE 80 SX	80	125	29	14,5	27	27	90,5	99,0	117	88,0	104	115	1,5	0,6	10	2,0	250.000	1.250.000	1,50
GE 90 SX	90	140	32	16,0	30	30	103,3	112	132	100,8	118	130	2,0	0,6	11	1,8	320.000	1.600.000	2,10
GE 100 SX	100	150	32	16,0	30	30	114,3	123	142	112,0	128	140	2,0	0,6	12	1,7	339.000	1.690.000	2,30
GE 110 SX	110	170	38	19,0	36	36	125,8	135	162	123,2	146	160	2,5	0,6	15	1,5	469.000	2.340.000	3,90
GE 120 SX	120	180	38	19,0	36	36	135,4	145	172	132,9	155	170	2,5	0,6	17	1,4	498.000	2.490.000	4,00
GE 130 SX	130	200	45	22,5	42	42	148,0	158	192	143,9	174	190	2,5	0,6	20	1,9	640.000	3.200.000	6,10
GE 140 SX	140	210	45	22,5	42	42	160,6	171	202	156,9	184	200	2,5	0,6	20	1,8	680.000	3.450.000	6,50
GE 150 SX	150	225	48	24,0	45	45	170,9	184	216	167,1	194	213	3,0	1	21	1,7	780.000	3.900.000	7,90
GE 160 SX	160	240	51	25,5	48	48	181,4	195	228	177,7	206	225	3,0	1	21	1,6	872.000	4.360.000	9,60
GE 170 SX	170	260	57	28,5	54	54	194,3	208	253	190,4	228	250	3,0	1	27	1,4	1.080.000	5.440.000	13,00
GE 180 SX	180	280	64	32,0	61	61	205,5	220	263	201,7	240	260	3,0	1	21	1,3	1.310.000	6.590.000	17,50
GE 190 SX	190	290	64	32,0	61	61	211,8	226	278	207,9	252	275	3,0	1	29	1,3	1.370.000	6.850.000	18,30
GE 200 SX	200	310	70	35,0	66	66	229,2	244	293	224,1	268	290	3,0	1	26	1,6	1.560.000	7.800.000	23,30

DIN ISO 12 240-2